

# Flangia a saldare di testa

Butt weld flange  
Bride à souder bout à bout  
Anschweisflansch

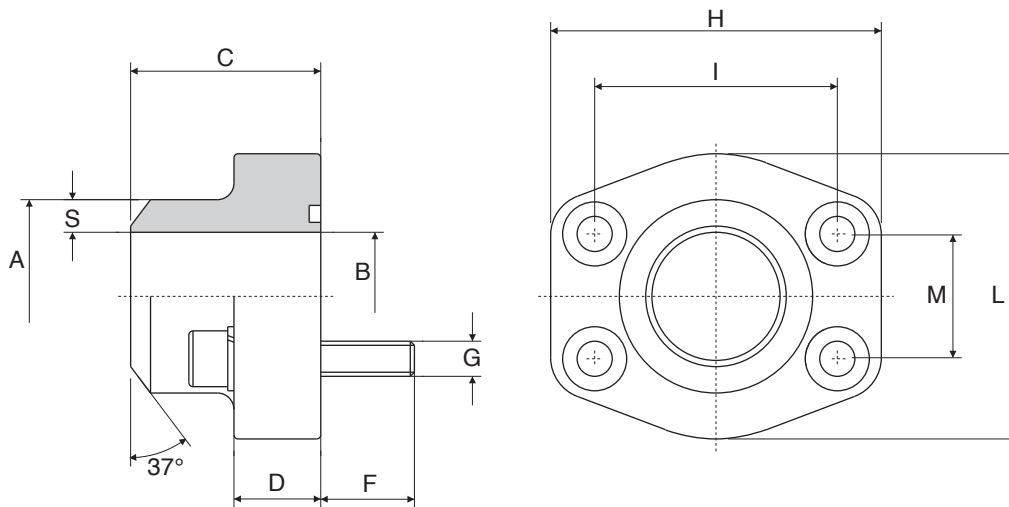

## Serie 3000 psi

Pressione max esercizio bar	Tipo Type	A	S.A.E.	B	C	D	S	F	G Viti / Bolts		H	I	L	M	OR O-RING
									Metr.	UNC					
348	C.F.S. 080-ST	17,5	3/8"	10	36	16	3,7	14	M 8	5/16"	57	38,1	47	17,5	4075
348	C.F.S. 080-ST	21,6	1/2"	13	36	16	4,3	14	M 8	5/16"	57	38,1	47	17,5	4075
348	C.F.S. 100-ST	27,2	3/4"	19	36	18	4,1	16	M10	3/8"	66	47,6	49	22,3	4100
348	C.F.S. 102-ST	34,5	1"	25	38	18	4,7	16	M10	3/8"	71	52,4	53	26,2	4131
278	C.F.S. 104-ST	42,8	1 1/4"	31	41	21	6	18	M10	7/16"	80	58,7	69	30,2	4150
210	C.F.S. 106-ST	48,6	1 1/2"	38	44	25	5,3	18	M12	1/2"	94	69,9	77	35,7	4187
210	C.F.S. 108-ST	61	2"	50	45	25	5,5	18	M12	1/2"	103	77,8	89	42,9	4225
175	C.F.S. 110-ST	76,6	2 1/2"	63	50	25	6,8	18	M12	1/2"	115	88,9	101	50,8	4275
138	C.F.S. 112-ST	89	3"	73	50	27	8	25	M16	5/8"	135	106,4	124	61,9	4337
35	C.F.S. 114-ST	103	3 1/2"	89	50	27	7	25	M16	5/8"	153	120,7	137	69,9	4387
35	C.F.S. 116-ST	115	4"	99	50	27	8	25	M16	5/8"	163	130,2	147	77,8	4437
35	C.F.S. 118-ST	141	5"	120	50	28	10,5	25	M16	5/8"	184	152,4	180	92,1	4537

## Serie 6000 psi

Pressione max esercizio bar	Tipo Type	A	S.A.E.	B	C	D	S	F	G Viti / Bolts		H	I	L	M	OR O-RING
									Metr.	UNC					
420	C.F.S. 401-ST	17,5	3/8"	10	36	16	3,7	14	M 8	5/16"	57	40,5	47	18,2	4075
420	C.F.S. 401-ST	21,6	1/2"	13	36	16	4,3	14	M 8	5/16"	57	40,5	47	18,2	4075
420	C.F.S. 402-ST	27,2	3/4"	18	36	19	4,6	16	M 10	3/8"	71	50,8	53	23,8	4100
420	C.F.S. 403-ST	34,5	1"	22	44	24	6,3	19	M 12	7/16"	80	57,2	66	27,8	4131
420	C.F.S. 404-ST	42,8	1 1/4"	28	44	27	7,2	22	M 14	-	94	66,6	77	31,8	4150
420	C.F.S. 404-STF133	42,8	1 1/4"	28	44	27	7,2	22	M 12	1/2"	94	66,6	77	31,8	4150
420	C.F.S. 405-ST	48,6	1 1/2"	32	51	30	8,3	24	M 16	5/8"	106	79,3	89	36,5	4187
420	C.F.S. 406-ST	61	2"	41	70	37	10	32	M 20	3/4"	135	96,8	116	44,5	4225
420	C.F.S. 408-ST	76,6	2 1/2"	50	75	45	13	40	M 24	-	166	123,8	150	58,7	4275
420	C.F.S. 410-ST	90	3"	58	90	55	16	55	M 30	-	208	152,4	178	71,4	4337

Per ordinazione flange: / Ordering Examples: / Pour commander brides: / Bestellbeispiel für Flansche:

Solo flangia .....CFS...ST Flangia completa di viti UNC, rondelle e OR .....CFS...ST-U Flangia completa di viti metriche, rondelle e OR .....CFS...ST-M  
 Only flange .....CFS...ST Complete flange with UNC screws, washers and o-ring .....CFS...ST-U Complete flange with metric screws, washers and o-ring .....CFS...ST-M  
 Seulement bride ...CFS...ST Bride complete des vis UNC, rondelles et OR .....CFS...ST-U Bride complete des vis métriques, rondelles et OR .....CFS...ST-M  
 Nur Flansch .....CFS...ST Flansch einschl. UNC-Schrauben, Federringen und O-Ring .....CFS...ST-U Flansch einschl. metrischen Zylinderschrauben, Federringen und O-Ring ...CFS...ST-M