

Doppie flange ISO 6164-'94 con coduli a saldare di testa

Double ISO 6164 -'94 flanges with butt welding adaptors

Doubles brides ISO 6164 -'94 avec collets bout à bout

Doppel ISO 6164 -'94 Anschweißflansche

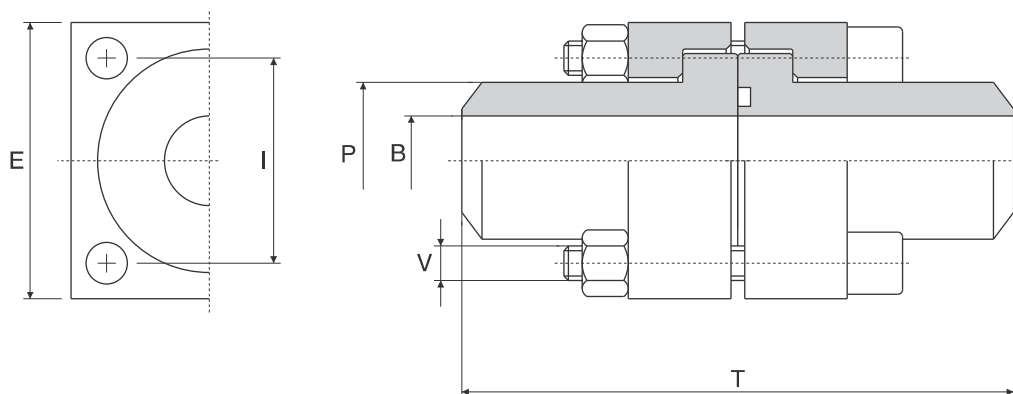

Serie 250 bar

Pressione max esercizio bar	Tipo Type	DN	Size	P	B	E	I	T	V	OR
										O-RING
250	64.L.10.DD	10	3/8"	17,5	10	40	24,7	80	M 6 x 45	3068
250	64.L.13.DD	13	1/2"	21,6	13	45	29,7	100	M 8 x 50	4075
250	64.L.19.DD	19	3/4"	27,2	19	50	35,4	120	M 8 x 55	4100
250	64.L.25.DD	25	1"	34,5	25	65	43,8	140	M10 x 65	4131
250	64.L.32.DD	32	1" 1/4	43	31	75	51,6	160	M12 x 75	4150
250	64.L.38.DD	38	1" 1/2	48,6	38	90	60,1	180	M16 x 90	4187
250	64.L.51.DD	51	2"	61	50	100	69,3	200	M16 x 100	4225
250	64.L.56.DD	56	2" 1/2	76	63	120	83,4	220	M20 x 120	4275
250	64.L.63.DD	63	3"	89	70	140	102,5	240	M20 x 140	4337
250	64.L.80.DD*	80	4"	114	90	160	113,5	280	M24 x 150	6387

*: non prevista da ISO 6164 - '94 / Not in ISO 6164 - '94

Serie 400 bar

Pressione max esercizio bar	Tipo Type	DN	Size	P	B	E	I	T	V	OR
										O-RING
400	64.S.10.DD	10	3/8"	17,5	10	40	24,7	80	M 6 x 45	3068
400	64.S.13.DD	13	1/2"	21,6	13	45	29,7	100	M 8 x 50	4075
400	64.S.19.DD	19	3/4"	27,2	18	50	35,4	120	M 8 x 55	4100
400	64.S.25.DD	25	1"	34,5	22	65	43,8	140	M10 x 65	4131
400	64.S.32.DD	32	1" 1/4	43	28	75	51,6	180	M12 x 75	4150
400	64.S.38.DD	38	1" 1/2	48,6	32	90	60,1	180	M16 x 90	4187
400	64.S.51.DD	51	2"	61	41	100	69,3	200	M16 x 100	6225
400	64.S.56.DD	56	2" 1/2	76,6	50	120	83,4	220	M20 x 130	6275
400	64.S.63.DD	63	3"	89	58	150	102,5	240	M24 x 140	6300
400	64.S.70.DD	70	3" 1/2	102	63	160	113,1	260	M24 x 150	6337
350	64.S.80.DD	80	4"	114	74	180	123,7	280	M30 x 180	6350

Per ordinare le flange
Ordering flanges
Pour commander brides
Bei bestellung Flanschen

Es.: 64.....DD